

Does your
shade seem
**TOO
SHORT?**
See p.4



Cellular • Pleated Installation Guide

Important: Your shade may take time to drop to the full length.
Fully extend the shade and allow the fabric to relax for 48 hours.



We make it easy!

Before starting

Your new Blinds To Go® shade is custom made to your specifications from the finest material available. The installation should be easy and your shade should fit beautifully.

Parts

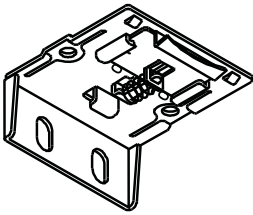

Regular single spring brackets
Quantity: 2 or more depending
on width of shade

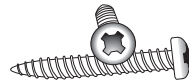

Mounting screws
Quantity: 2 for each bracket

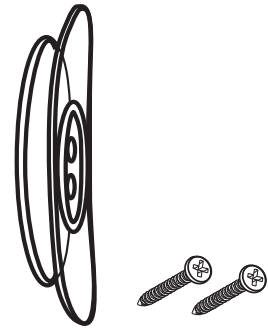

Cord cleat and screws
Quantity: 1 set

Optional Hardware *(only provided for specific applications)*

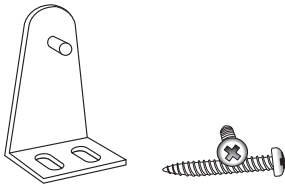

Hold down brackets and screws
Quantity: 2 sets

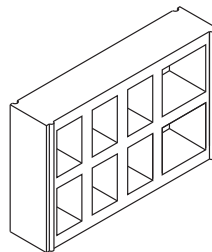

Spacer blocks *(optional)*
Quantity: 1 for each regular bracket

Note: Mounting screws provided are suitable for most mounting surfaces. See below for additional suggestions.

For wallboard or plaster: Use hollow wall anchors provided for added support.

For concrete, stone, brick or tile: Use a carbide drill and appropriate anchors before fastening the screws.

For metal surfaces: Pre-drill holes before fastening the screws.

Suggested Tools

- Drill
- Level
- Pencil
- Screwdriver
- Tape measure

Getting started

Step 1. Mounting brackets

1. Hold the shade where you want to mount it and mark **approximately 4-4½"** in from each end of the headrail. This is where your brackets will go. We recommend you use a level to ensure bracket alignment.

When more than two brackets are supplied, position the additional brackets **evenly between** the two end brackets.

Important: Under all circumstances, the brackets should be positioned to avoid interfering with the operating components in the headrail.

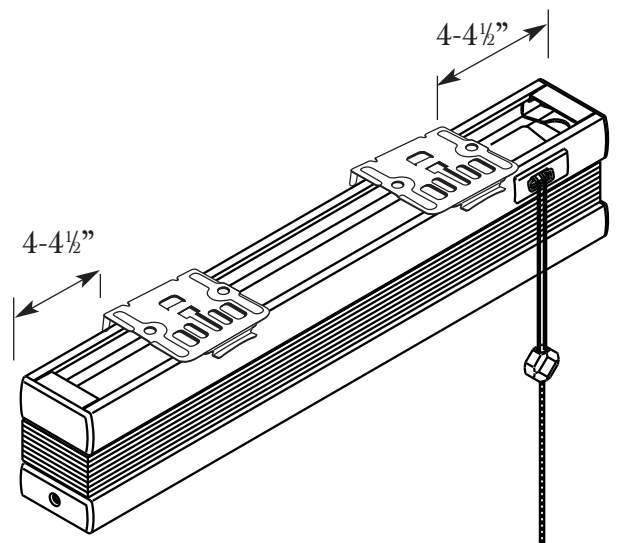

2. Mount the brackets as illustrated.

inside mount

(Shade is mounted inside the window frame, either at the top or to the two sides of the frame)

outside mount

(Shade is mounted either on or outside the window frame)

For the shade to be flush within the frame, the front edge of the brackets should be flush with the front edge of the frame.

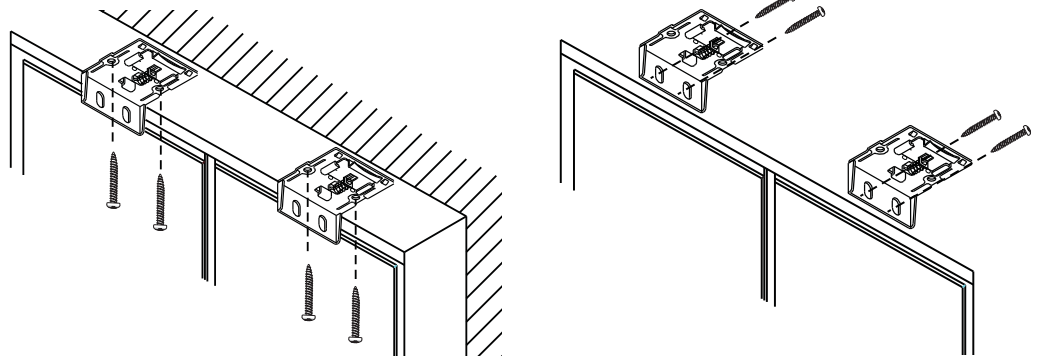

Note: If you have ordered spacer blocks, apply as illustrated.

applying spacer blocks (optional)

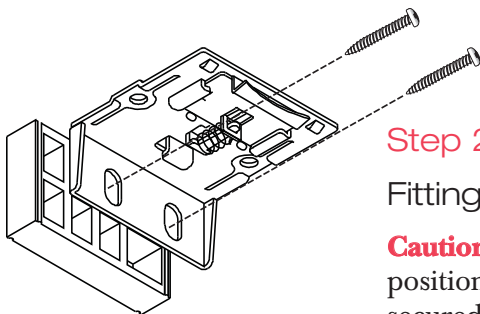

Step 2.

Fitting the shade into the brackets

Caution: Make sure the shade is in the closed position until brackets and headrail are properly secured.

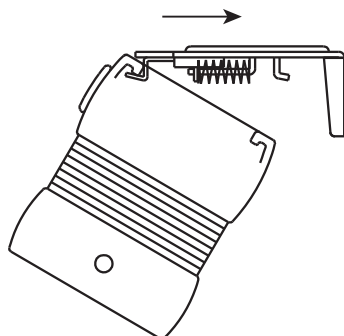
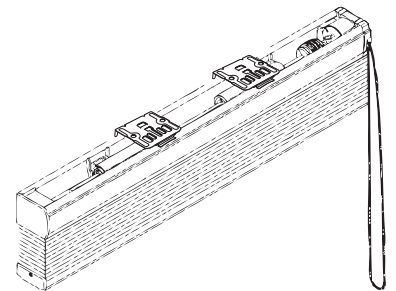

Fig. (A)

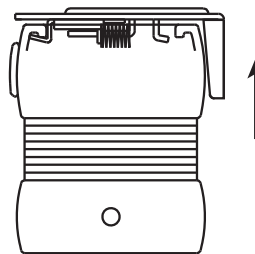

Fig. (B)

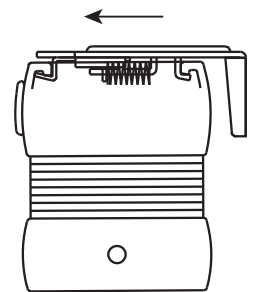

Fig. (C)

1. See (Fig. A). Insert the front of the headrail at an angle to the front lip on the bracket.
2. See (Fig. B). Push the headrail in and rotate the back upward so that it is flush against the bracket.
2. See (Fig. C). Release the pressure on the front of the headrail, allowing it to slide forward and snap into the bracket.

Note: To remove the shade, while pushing back on the shade to disengage back locking tab, rotate the back of the headrail down. The shade should then release out of the brackets.

Step 3. Mounting the cord cleats *(child safety measure)*

This cleat is to be used when there is excessive cord dangling, especially when the shade is in the raised position. This helps reduce the risk of a child playing with loose cords.

1. Mount the cleat near the shade, out of reach of children. The exact location of the cord cleat is not critical, it can be mounted inside the frame, on the frame or outside the frame.
2. Wrap the excess cord around the installed cleat as illustrated.

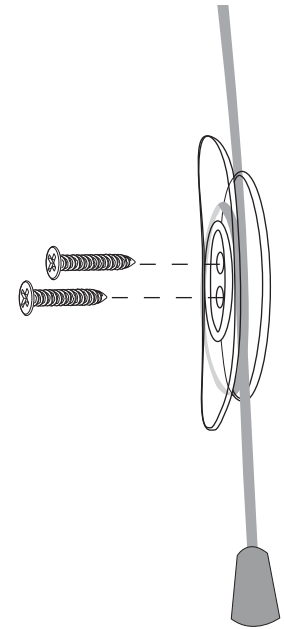

Step 4. Mounting hold down brackets *(optional, only if ordered)*

1. Lower the shade to the desired height. Position the hold down bracket to align the tab to the holes of the end caps of the bottom rail.

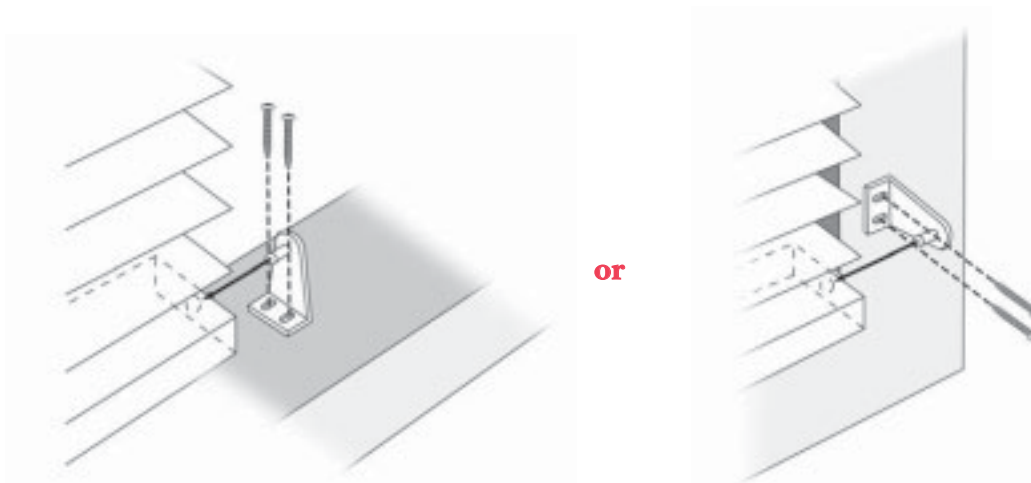

2. Mount the brackets as illustrated.

IMPORTANT OPERATING INSTRUCTIONS

1. To prevent the shade from hanging unevenly, this product **MUST** be raised and lowered from the middle of the bottom rail. To straighten a shade hanging unevenly, fully extend it and then raise it from the middle. Do not lift quickly as this creates slack in the ribbons.
2. When over-extended, the shade will creep back to the designed length. This is not a defect but is a function of how the shade operates.
3. When unused for an extended period of time, fully extend the shade, then gently raise and lower 3 – 5 times. This will return the shade to its optimum operating performance.

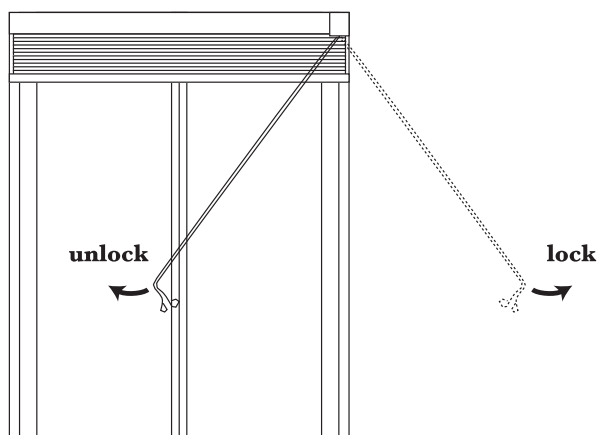

Fabric pleats can take up to 48 hours to fully extend!
If your shade appears SHORT:

1. Unlock the cordlock mechanism as shown at left.
2. While holding the cord **toward** the center of the shade with one hand, use your other hand to grasp the middle of the bottom bar, pulling down the shade as far as it will go.
3. Let hang for **48 hours**.